

*Phase leg  
Trench IGBT® Power Module*

**$V_{CES} = 1700V$   
 $I_C = 75A @ T_c = 80^\circ C$**

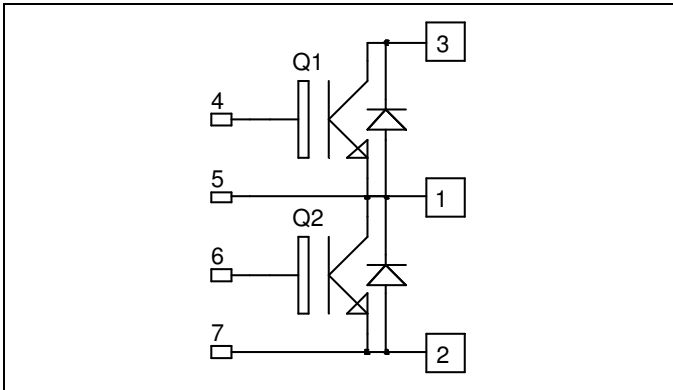

**Application**

- Welding converters
- Switched Mode Power Supplies
- Uninterruptible Power Supplies
- Motor control

**Features**

- Trench + Field Stop IGBT® Technology
  - Low voltage drop
  - Low tail current
  - Switching frequency up to 20 kHz
  - Soft recovery parallel diodes
  - Low diode VF
  - Low leakage current
  - Avalanche energy rated
  - RBSOA and SCSOA rated
- Kelvin emitter for easy drive
- Low stray inductance
- High level of integration
- Kelvin emitter for easy drive
- Low stray inductance
  - M5 power connectors

**Benefits**

- Stable temperature behavior
- Very rugged
- Direct mounting to heatsink (isolated package)
- Low junction to case thermal resistance
- Easy paralleling due to positive TC of VCEsat

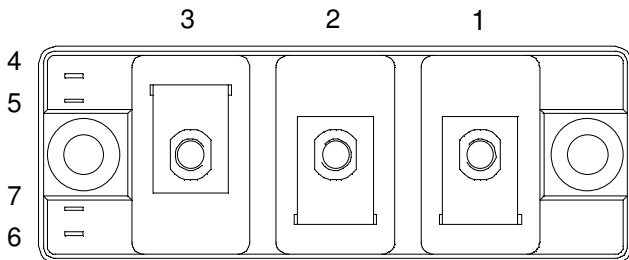

**Absolute maximum ratings**

Symbol	Parameter	Max ratings	Unit
$V_{CES}$	Collector - Emitter Breakdown Voltage	1700	V
$I_C$	Continuous Collector Current	$T_C = 25^\circ C$	120
		$T_C = 80^\circ C$	75
$I_{CM}$	Pulsed Collector Current	$T_C = 25^\circ C$	150
$V_{GE}$	Gate - Emitter Voltage	$\pm 20$	V
$P_D$	Maximum Power Dissipation	$T_C = 25^\circ C$	520
RBSOA	Reverse Bias Safe Operation Area	$T_j = 125^\circ C$	150A@1700V

**CAUTION:** These Devices are sensitive to Electrostatic Discharge. Proper Handling Procedures Should Be Followed.

All ratings @  $T_j = 25^\circ\text{C}$  unless otherwise specified

## Electrical Characteristics

Symbol	Characteristic	Test Conditions	Min	Typ	Max	Unit
$BV_{CES}$	Collector - Emitter Breakdown Voltage	$V_{GE} = 0\text{V}, I_C = 3\text{mA}$	1700			V
$I_{CES}$	Zero Gate Voltage Collector Current	$V_{GE} = 0\text{V}, V_{CE} = 1700\text{V}$			5	mA
$V_{CE(on)}$	Collector Emitter on Voltage	$V_{GE} = 15\text{V}$		2.0	2.4	V
		$I_C = 75\text{A}$	$T_j = 25^\circ\text{C}$			
				2.4		
$V_{GE(th)}$	Gate Threshold Voltage	$V_{GE} = V_{CE}, I_C = 3\text{mA}$	5.2	5.8	6.4	V
$I_{GES}$	Gate - Emitter Leakage Current	$V_{GE} = 20\text{V}, V_{CE} = 0\text{V}$			400	nA

## Dynamic Characteristics

Symbol	Characteristic	Test Conditions	Min	Typ	Max	Unit
$C_{ies}$	Input Capacitance	$V_{GE} = 0\text{V}, V_{CE} = 25\text{V}$ $f = 1\text{MHz}$		6.5		nF
$C_{res}$	Reverse Transfer Capacitance			0.22		
$T_{d(on)}$	Turn-on Delay Time	Inductive Switching ( $25^\circ\text{C}$ ) $V_{GE} = \pm 15\text{V}$ $V_{Bus} = 900\text{V}$ $I_C = 75\text{A}$ $R_G = 18\Omega$		200		ns
$T_r$	Rise Time			100		
$T_{d(off)}$	Turn-off Delay Time			750		
$T_f$	Fall Time			100		
$T_{d(on)}$	Turn-on Delay Time	Inductive Switching ( $125^\circ\text{C}$ ) $V_{GE} = \pm 15\text{V}$ $V_{Bus} = 900\text{V}$ $I_C = 75\text{A}$ $R_G = 18\Omega$		230		ns
$T_r$	Rise Time			100		
$T_{d(off)}$	Turn-off Delay Time			900		
$T_f$	Fall Time			120		
$E_{off}$	Turn Off Energy			25		mJ

## Reverse diode ratings and characteristics

Symbol	Characteristic	Test Conditions	Min	Typ	Max	Unit	
$V_F$	Diode Forward Voltage	$I_F = 75\text{A}$ $V_{GE} = 0\text{V}$	$T_j = 25^\circ\text{C}$		1.8	2.2	V
			$T_j = 125^\circ\text{C}$		1.9		
$E_r$	Reverse Recovery Energy	$I_F = 75\text{A}$ $V_R = 900\text{V}$ $di/dt = 990\text{A}/\mu\text{s}$	$T_j = 25^\circ\text{C}$		10		mJ
			$T_j = 125^\circ\text{C}$		17.5		
$Q_{rr}$	Reverse Recovery Charge	$I_F = 75\text{A}$ $V_R = 900\text{V}$ $di/dt = 990\text{A}/\mu\text{s}$	$T_j = 25^\circ\text{C}$		20		$\mu\text{C}$
			$T_j = 125^\circ\text{C}$		32		

## Thermal and package characteristics

Symbol	Characteristic	Min	Typ	Max	Unit	
$R_{thJC}$	Junction to Case	IGBT			0.24	$^\circ\text{C}/\text{W}$
		Diode			0.42	
$V_{ISOL}$	RMS Isolation Voltage, any terminal to case $t = 1$ min, $I_{isol} < 1\text{mA}, 50/60\text{Hz}$	3500			V	
$T_J$	Operating junction temperature range	-40		150	$^\circ\text{C}$	
$T_{STG}$	Storage Temperature Range	-40		125		
$T_C$	Operating Case Temperature	-40		125		
Torque	Mounting torque	For terminals	M5	2	3.5	N.m
		To Heatsink	M6	3	5	
Wt	Package Weight			180	g	

